

# 5FG/5FD

ENGINE POWERED FORKLIFT

5.0 to 8.0 ton  
SERIES



 TOYOTA



# THE TOYOTA THEORY OF EVO

A Triumph of Stability and Performance



Toyota introduces a new breed of high-performance trucks for an ever-more demanding market — the new engine-powered pneumatic tire 5-8 ton forklift series. A triumph of advanced technology and an ongoing commitment to improvement, this series features a safe and solid design and a stability that inspires reliability and job confidence. A wide range of model sizes lets you choose the best for the job at hand. No matter which you select, all members of this series exemplify the Toyota theory of evolution — solid comfort and steady performance. These forklifts point the way to the future — the ideal trucks to get the job done at your worksite, with efficiency and plenty of comfort.

**LUTION**

# PROGRESS WITHOUT CO

The tasks performed by forklifts are grueling — no doubt about it. What's more, the bone-rattling vibration and constant noise of most large forklifts are hard to ignore — just ask any operator. But just because the forklift must stand up to the most punishing tasks, it doesn't mean the operator must take it, too. Toyota thinks of the operator first and foremost. This concern for the forklift operator shows in the Toyota design, offering a stability and solidity of construction that inspires confidence and reliability...and a good deal of comfort besides.

Toyota's state-of-the-art technology has endowed the 5-8 ton series with the newly developed engine. This rugged powerhouse delivers dramatically high efficiency together with outstanding fuel economy, and features minimized vibration and noise for a more comfortable ride — another victory of Toyota's drive to blend the latest technical advances with enduring comfort for the operator.



# COMFORT? NOT AT TOYOTA



## A Full-Floating System for Uncompromising Comfort

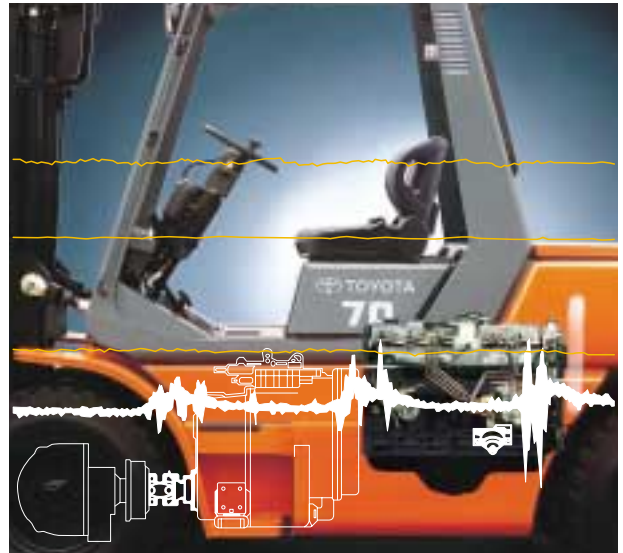

The new series uses a full-floating system that vastly reduces the amount of engine vibration transmitted to the frame, assuring a ride of unmatched comfort. This promises not only more comfort for the operator, but greater frame durability as well.

At Toyota, advanced technology goes hand in hand with superior comfort. That is the concept of TECHNO-COMFORT — the idea that the benefits of our ongoing technical development are ultimately for the operator.

The full thrust of the leading-edge technology harnessed under Toyota's TECHNO-COMFORT concept has come to fruition in the creation of this new 5-8 ton forklift series, a crowning achievement in Toyota's drive to wed high performance with unbeatable comfort.

# TOYOTA QUALITY: ALWAYS A STEP AHEAD

## PERFORMANCE



**A Engine:** Diesel models use the massive 5.2 liter 14Z six-cylinder engine to provide power to spare. Despite its large size, the 14Z boasts of low exhaust emissions. The time-proven 3F engine ensures responsive performance.



**B Powershift Transmission:** The advanced Self-Moving Hydrodynamic Drive (SMHD) gives smooth yet powerful acceleration response. The SMHD features a single speed in both forward and reverse, helping to reduce work for the operator.

The shift lever can be operated with just the finger tips, boosting handling efficiency while reducing operator fatigue.



## DURABILITY

**A Hydraulic Circuit:** A tandem oil pump equipped with a flow control valve is used. The torque converter powers the pump, and the arrangement of the hydraulic piping helps minimize pressure loss together with preventing excessive rises in the temperature of the hydraulic oil, boosting the lifespan of hydraulic components.

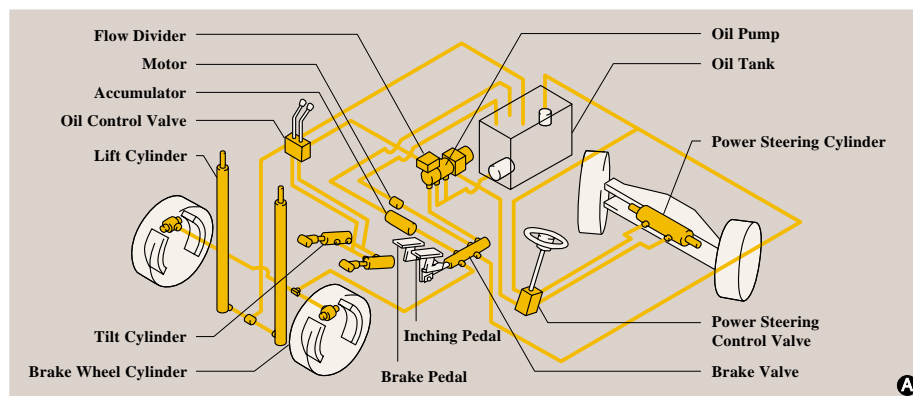

**B Air Intake:** To ensure a supply of clean air for the engine, a snorkel air intake is located on the upper porting of one of the pillars for the operator's headguard. An 8" cyclone air cleaner featuring outstanding air cleaning efficiency is used. A warning light

on the Integrated Monitoring Center tells the operator when the element needs cleaning.

## COMFORT

**Ⓐ Instruments:** All controls and pedals are laid out for optimized ease of use. The layout of meters and gauges in an integrated combination panel makes it simple to monitor functioning at a glance, and the greater variety of meters used assures a better awareness of vehicle status at all times.

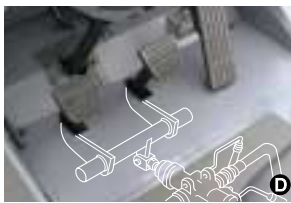

**Ⓑ Driving Area:** A comfortable space with plenty of room is ensured for the operator. Combined with the floating power train and body, this makes for an area highly conducive to operations with outstanding accuracy and safety.

**Ⓒ Steering:** The small-diameter steering wheel and hydrostatic steering system assure outstanding handling with minimum effort. The steering column can also be tilted steplessly along a 68 mm (2.7 in) range for optimum comfort.

**Ⓓ Pedals:** Fatigue is minimized through the use of floor-mounted pedals.

**Ⓔ Seat:** This side-wing and seat-belt equipped Operator Restraint System (ORS) seat wraps the operator in both safety and comfort. It offers step-less adjustment 120 mm (4.7 in) longitudinally and is complemented by the small-diameter steering wheel on a tiltable column.

A suspension seat is optionally available.

## SERVICEABILITY

**Ⓐ Engine Hood:** The engine hood is completely sealed for maximum comfort, and opens fully to a wide 85°. A hood damper reduces the effort needed to open the hood to a paltry 10 kg (22 lb) or so.

**Ⓑ Radiator Cover:** A sealed design is used for the radiator cover as well, and easy access is assured by the handy damper, which makes opening and closing the cover a snap.



# MODEL VARIATION



## MAIN SPECIFICATIONS

Model		5FG/5FD50	5FG/5FD60	5FD70	60-5FD80
Engine Model		3F, 14Z	3F, 14Z	14Z	14Z
Load Capacity	kg	5000	6000	7000	8000
	lb.	11000	13000	15500	18000
Load Center	mm	600	600	600	600
	in.	24	24	24	24
Overall Width	A mm	1995	1995	1995	2160
	in.	78.5	78.5	78.5	85
Turning Radius (Outside)	B mm	3350	3350	3400	3700
	in.	132	132	134	146
Overhead Guard Height	C mm	2440	2440	2440	2615
	in.	96	96	96	103
Length to Fork Face	D mm	3460	3505	3585	3930
	in.	136	138	141	154.5

## ENGINE SPECIFICATIONS

Model		TOYOTA 3F Gasoline
Piston Displacement	cc	3955
	cu-in	241
Rated Horsepower/r.p.m.	SAE HP	74/2300 Net
	JIS ps	75/2300
Rated Torque/r.p.m.	SAE ft-lb	188/1200 Net
	JIS kg-m	26/1200

Model		TOYOTA 14Z Diesel
Piston Displacement	cc	5204
	cu-in	317
Rated Horsepower/r.p.m.	SAE HP	94 (99)/2200 (2400) Net
	JIS ps	95 (100)/2200 (2400)
Rated Torque/r.p.m.	SAE ft-lb	253/1600 Net
	JIS kg-m	35/1600

( ) for 60-5FD80.

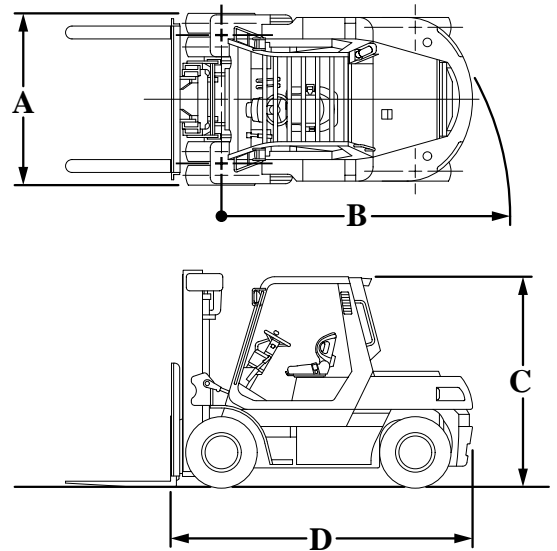

Availability and specifications are determined regionally and are subject to change without notice. Please consult your Toyota representative for details.

Printed on recycled paper.  
All rights reserved by Toyota Industries Corporation.



**TOYOTA Material Handling Company**

A Division of TOYOTA INDUSTRIES CORPORATION

CAT.5-8 TON SERIES/E-0211/©/Printed in Japan/No.710380E0/1,300